



Structural strengthening of a historical building in Rio Branco city – Acre

D. C. S. Amorim¹, D. R. C. Oliveira¹

¹ Civil Engineering Post-graduation Program, Federal University of Para, Brasil.

Article information

DOI:

<http://dx.doi.org/10.21041/ra.v5i2.82>

Article received on December 01, 2014, reviewed under the publishing policies of ALCONPAT Journal and accepted on March 30, 2015. Any discussion, including the replica of the authors, shall be published in the second number of the year 2016 as long as the information is received prior to the closing of the first number of the year 2016.

© 2015 ALCONPAT Internacional

Legal Information

ALCONPAT Journal, Year 5, No. 2, May – August 2015, is a quarterly publication of the Latin American Association of Quality Control, Pathology and Construction Recovery, International, A.C., Km. 6, Old Highway to Progreso, Mérida, Yucatán, Zip Code 97310, Tel. +52 1 (999) 738-5893, alconpat.int@gmail.com.
Website: www.alconpat.org
Responsible Editor: Dr. Pedro Castro Borges. All rights reserved for exclusive use, No. 04-2013-011717330300-203, eISSN 2007-6835, both granted by the National Institute of Copyright.
Responsible for the last update of this number, Informatics Unit ALCONPAT, Elizabeth Sabido Maldonado, Km. 6, Old Highway to Progreso, Mérida, Yucatán, Zip Code 97310, publication date: May 30, 2015.

The opinions expressed by the authors do not necessarily reflect the stance of the editor.

The total or partial reproduction of the contents and images of this publication without the prior authorization of ALCONPAT International A.C. is prohibited.

ABSTRACT

This work presents the use of the technique of structural reinforcement for jacketing applied in the reform of the historical building called "Casarão", due to the architectural need to remain as faithful to the original design, justifying the need for increased resilience without substantial increase in the cross section of the pillars. The results obtained by analyzing the reinforcement relative to rectangular columns subjected to bending, shearing and torsional, in accordance with the NBR 6118 (ABNT, 2014), indicated that the studied technique was efficient because all reinforced parts had a greater bearing capacity and met the current requirements without compromising the structural safety of the building's characteristic architectural.

Keywords: historical building; structural strengthening; jacketing.

RESUMO

Este trabalho apresenta o emprego da técnica de reforço estrutural por encamisamento aplicada na reforma da edificação histórica denominada "Casarão", devido à necessidade arquitetônica de permanecer o mais fiel ao projeto original, justificando-se pela necessidade do aumento de capacidade de resistência sem que haja aumento substancial na seção transversal dos pilares. Os resultados obtidos através da análise do reforço em relação aos pilares retangulares submetidos à flexão composta, esforços cortantes e torsores, em concordância com a NBR 6118 (ABNT, 2014), indicaram que a técnica estudada foi eficiente, pois todas as peças reforçadas tiveram uma capacidade portante maior e atenderam aos requisitos atuais de segurança estrutural sem comprometer as características arquitetônicas da edificação.

Palavras-chave: edificação histórica; reforço estrutural; encamisamento.

RESUMEN

Este artículo presenta el empleo del método de refuerzo estructural por revestimiento aplicada en la reforma del edificio histórico llamado "Casarão" en portugués, debido a la necesidad arquitectónica de permanecer tan fiel al diseño original, justificado por el interés de aumento de resistencia sin aumento sustancial de la sección transversal de los columnas. Los resultados obtenidos mediante el análisis del refuerzo con relación a las columnas rectangulares sometidos a flexión compuesta, esfuerzos de cizallamiento y de torsión, de acuerdo con la NBR 6118 (ABNT, 2014), indican que la método estudiada fue eficiente, porque todas las partes reforzadas tuvieron una mayor capacidad portante y cumplieron con los requisitos actuales de seguridad estructural, sin comprometer las características arquitectónicas del edificio.

Palabras clave: edificio histórico; refuerzo estructural; revestimiento.

Corresponding author: Denis Cley Souza Amorim (deniscley25@yahoo.com.br)

1. INTRODUCTION

The "Casarão" (Figure 01), public building built in the 1930s, has mixed structure of reinforced concrete and wood in good condition in its central part, maintaining eclectic Syrian and Lebanese architectural features with European influence, representing a regional style of great cultural importance of the city of Rio Branco, in Acre state. Its revitalization meets a society demand for the state government, which received a petition with hundreds of signatures to this choice. The historic building was listed by the State Board of Historical and Cultural Heritage on August 13, 2009, at the initiative of civil society, and approved on April 30, 2010, by the decree number 5,235, under the protection and supervision of the state government, through the Department of History and Cultural Heritage Foundation of Culture and Communication Elias Mansour.



Figure 1. The Casarão.

In this case study, the building's columns were analytically and computationally evaluated to check their resistance, to meet the existing requirements of structural safety. As well as several old buildings in the city of Rio Branco, the concrete of these columns was dosed with brick shards as coarse aggregate to replace commonly used ones, such as pebble and gravel. There is no technical evidence of the strengthening of this material to meet the NBR 6118 (ABNT, 2014), testimonies extraction procedures were performed and the results showed compression strength of concrete below the specified on the structural revitalization project of the building, carried out with the help the computer program. The verification of the results of this enhancement becomes important because jacketing technique with reinforced concrete is the most common and also presents implementation difficulties in historical buildings works due to architectural necessity, considered culturally indispensable to the architectural heritage of the city and should remain as true to its original form, without any substantial increase in the cross section of the columns, the jacketing of reinforced concrete is feasible due to economic advantages, speed of execution and consistency with the architectural design.

2. METHODOLOGY

2.1 Characteristics of the historical building.

The building to be revitalized is called Casarão and is located at Brazil avenue number 310 in the city of Rio Branco, Acre state. Featuring 405.1 m² of built area, the Casarão is composed of basement, ground floor and upper floor, with a parking with 705.0 m² and a free area of 154.7 m² in front of the building. All stages of the building revitalization process were the Acre State Government responsibility and followed an executive chronogram previously established and detailed. The municipal director plan, by law 1611 of 27 October 2006, classified Casarão as a building located in ZPHC (Cultural Historic Preservation Zone), with occupancy rate of 70% (810.0 m²), coefficient of utilization 6 (7800.0 m²) and 10% of permeability rate (130.0 m²). During the process of revitalization it was found the need for structural strengthening only for the underground stretch of the columns P21, P30 and P41 for new loadings, which did not occur with the other columns. Figure 2 (top floor wood molds) shows the original situation of the columns and the strengthening proposal.

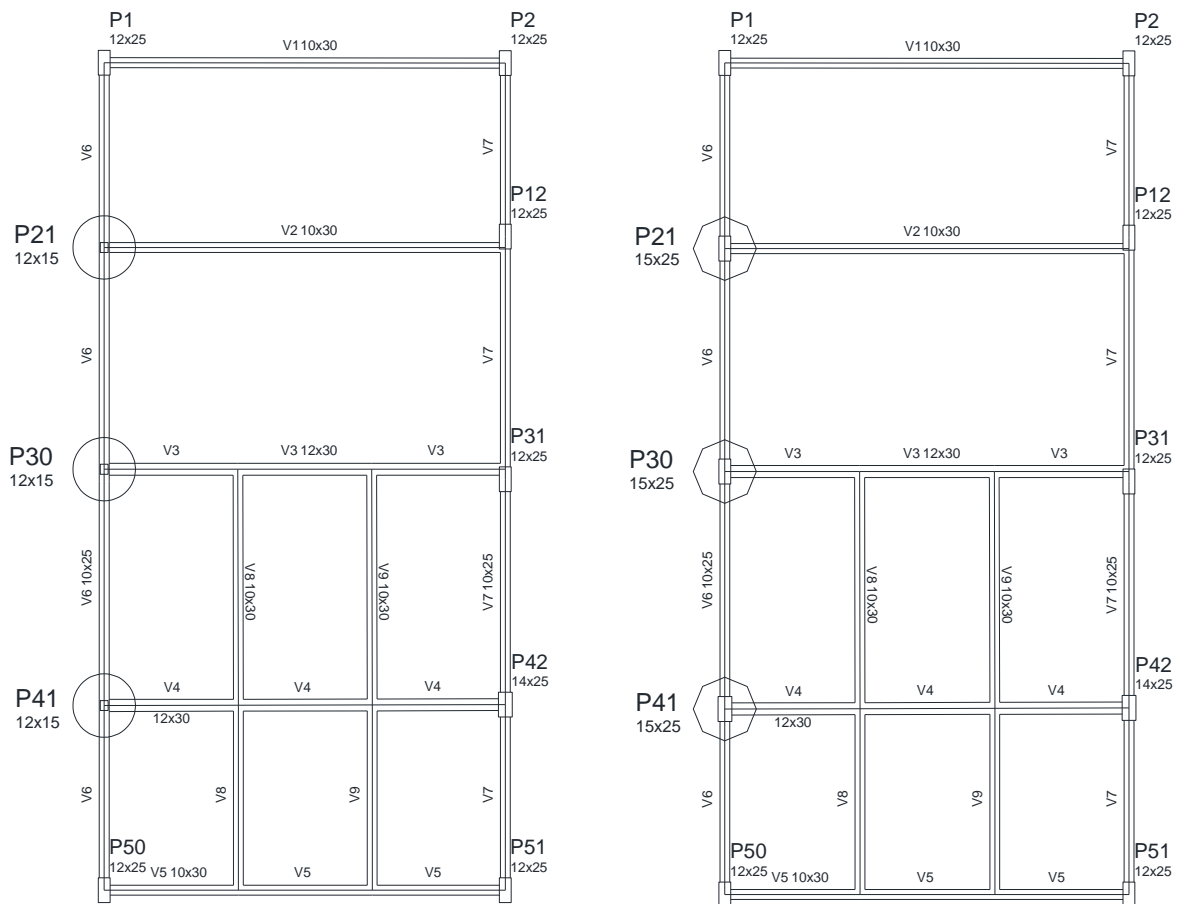

Figure 2. Location and dimensions of columns P21, P30 and P41 before and after structural strengthening (right).

In the reform of the building, period features have been retained and built-up areas that were not in the original architectural design have been removed. The services performed were the revitalization of the original wood walls, structural strengthening of the columns, replacement of

the roof structure, the roof, the floorboards of the ground and upper floors, replacement of electric installations, logic, water and sewer pipes, fire-fighting system, creating a seating area with benches and bins, maintenance of three rooms upstairs and manufacture of masonry in the three floors. Figure 3 shows the appearance of the side and front facades of the revitalization project.



Figure 3. Final aspect designed for Casarão.

2.2 The finding of the problem.

To check the existing structural safety, inspection visits and monitoring of the construction site during the execution of the revitalization work were carried out, where the procedures, techniques and equipment used in operations were identified and the photographic record being held at all stages of the executive process in 2009 and 2010. Before performing any procedure on the structure, the technical team highlighted the importance of axial compression tests on concrete testimonies to enable identification of any eventual problems related to concrete strength, since the old concrete was originally made with ceramic pieces of bricks and roof tiles. The test results indicated that, in general, the structural concrete has low compressive strength and contained coarse aggregate larger than 50 mm, which contributed to the formation of voids inside of some columns. It notes that the use of coarse aggregates derived from reducing of ceramic elements such as bricks and tiles is still a common practice in the city of Rio Branco, where there is shortage of gravel and rolled pebble. Figure 4 shows the location of extraction of the concrete testimonies in a column and Table 1 shows the results for concrete compressive strength of concrete testimonies from columns P21, P30 and P41, which further analysis indicated the need for structural strengthening in the basement level columns.

Besides the low compressive strength, it was also found that the reinforcements of some columns had advanced corrosion and severe weight loss, compromising bearing capacity to service loadings and even to permanent ones, once some bars were completely sectioned by corrosion. Figure 5 shows the appearance of the corroded reinforcement bars of the columns. It was concluded that the damage was characteristic of deterioration processes with systemic nature, i.e. related to the quality of the concrete used in the manufacturing of the structural system and

especially the thickness of reinforcements coatings that showed values between 10 mm and 15 mm, considered inadequate to provide the required service life of a structure made of concrete containing such porous aggregates.



Figure 4. Testimonies' extraction hole in a column.

Table 1. Concrete's compressive strength.

Pilar	Testemunhos (MPa)	Projeto de reforço (MPa)
P21	13.7	25.0
P30	20.1	
P41	14.7	
Average	16.2	



Figure 5. Columns' longitudinal reinforcement eroded (corrosion).

2.3 Structural strengthening.

The applied methodology for defining the structural strengthening technique considered the set of information on the conservation status of the entire structure in order to drive the strengthening

designer engineer to draw up a more accurate diagnosis of the causes and consequences of the pathologies found, because, according to Julio *et al.* (2003), the success of rehabilitation activities or intervention in the structure depends on a clear and precise definition about the problems encountered, including a diagnosis and prognostic evaluation of the acting causes. This preliminary study was instrumental in determining the level of intervention to be performed in the structure, which can range from simple repairs located to the need for demolition and reconstruction. For structural reinforcement was chosen the reinforced concrete jacketing technique, as the concrete can be cast into molds or projected, making it the most versatile material for the enhancement or restoration of reinforced concrete structures, and used in all kinds of structural elements and in different situations and conditions (Mehta & Monteiro, 2014). The structural reinforcement was then indicated to the columns P21, P30, P41, in the basement floor lengths, with the main steps consist of superficial concrete scarification, positioning of additional reinforcement, installation of wooden molds and placing of concrete with compressive strength (f_{ck}) of 25 MPa.

2.3.1 Concrete. The concrete used for structural strengthening was monitored and supervised following the recommendations of the Brazilian standard for concrete structures design, NBR 6118 (ABNT, 2014), and the design of the concrete mix to reach the compressive strength of concrete (f_{ck}) 25 MPa provided the volume ratio of 1: 2: 3 with water/cement factor of 0.5 using coarse aggregate maximum diameter of 9.5 mm. Verification of the compressive strength of concrete was performed by specialized laboratory that conducted the casting "in loco" of cylindrical proofs with 100 mm diameter and 200 mm height. Three proofs were molded from each concreted held by employees of the executive company of the structural strengthening, who received training and quality control so that the concrete mix reached the compressive strength specified by the designer of the structural strengthening.

2.3.2 Reinforcements. The longitudinal and transverse reinforcement (stirrups) before and after the structural strengthening of the columns were composed of steel bars with diameters, numbers and spacing presented in Table 2. The concrete cover for the columns was 25 mm and 15 mm at the short and long sides' dimensions, respectively. Figure 6 shows details of the cross sections of the columns before and after the structural strengthening with reinforced concrete jacketing, and Figure 7 shows details of the transverse and longitudinal bars. The columns P21, P30 and P41 were only strengthened in the basement floor length because these columns presented safety factors below the recommended by the Brazilian standard for reinforced concrete structures design for the future loadings. Figure 8 shows the placement of the reinforcements, where it is possible to see that, despite efforts to preserve as much original architecture, the smaller final dimensions of the columns, plus the 20 mm thick coating mortar layer, would be greater than the wall thickness.

Table 2. Columns' cross section dimensions and reinforcements.

Column	Columns dimensions		Steel		
	Cross section (mm)		Reinforcement (mm)		Design yield stress (MPa)
	Original	Strengthening	Original: Longitudinal / Stirrups	Strengthening: Longitudinal / Stirrups	
P21	120 x 150	150 x 250	4Ø10.0 / Ø5.0e150	4Ø12.5 / Ø5.0e150	435
P30					
P41					

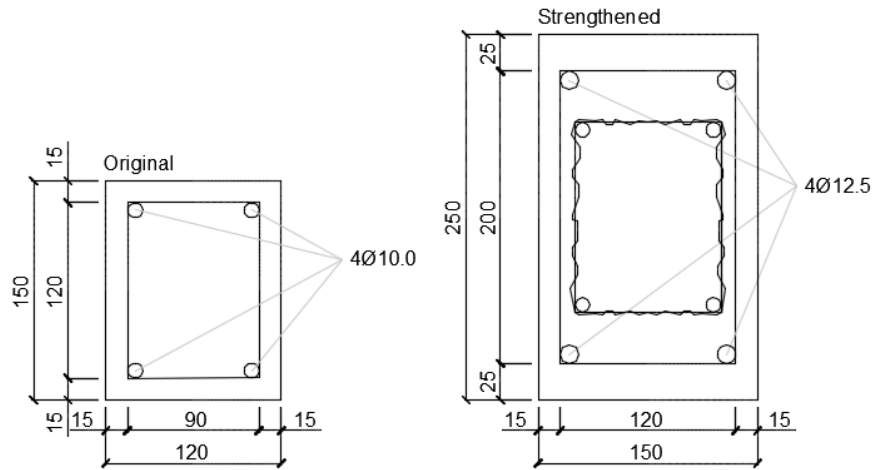

Figure 6. Columns' cross section before and after the structural strengthening.

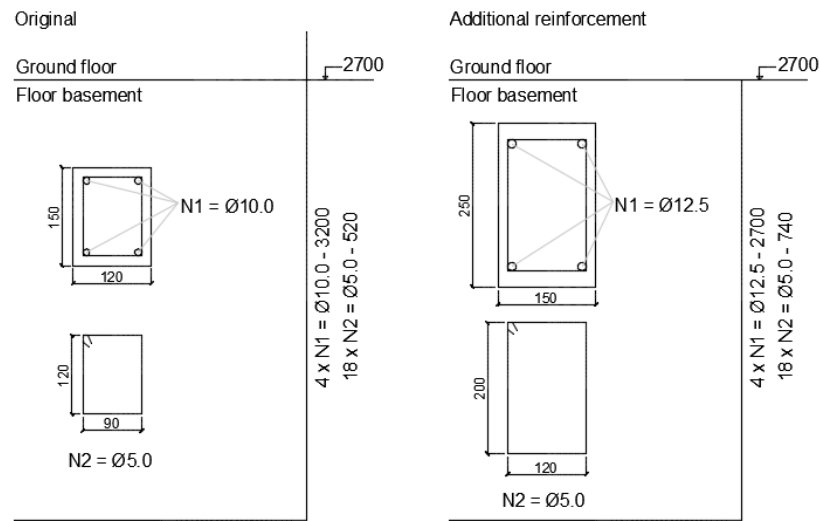

Figure 7. Original and additional reinforcement.



Figure 8. Longitudinal reinforcement and stirrups of the structural strengthening.

2.3.3 Concrete casting. So that there was greater adherence between the old and new concrete its surfaces of the columns were wet before the concrete casting. The concrete was carefully released (Figure 9) and the density was achieved with immersion vibrator with a head diameter of 20 mm, first in 50% of the volume of concrete cast in each column and then the remaining volume. After removal of the wooden mold the columns received a mortar coating layer to allow the finishing, or painting. Figure 10 shows the final appearance of the columns with smaller dimensions exceeding in 35 mm the wall thickness.



Figure 9. Concrete casting of the structural strengthening.



Figure 10. Final aspect of the strengthened columns.

3. RESULTS AND DISCUSSION

3.1 Current columns' safety evaluation.

The calculation methodology to check the columns' safety with and without structural strengthening followed the prescriptions of NBR 6118 (ABNT, 2014). A simplified analysis which were determined and compared only the normal loading and resistant capacity for P21, P30

and P41 columns before the strengthening with its normal loading force multiplied by γ_u (Equation 1) and an additional increase coefficient (Equation 2). Since design normal resistant force was determined by Equation 3, Equation 4 was used to determine the concrete's design compressive strength (f_{cd}) and Equation 5 enables the determination of the safety factor for each column.

a) Cross section's parameters. The cross section of solid columns and wall-columns, whatever its form, should not present dimension smaller than 190 mm. As the smallest dimension of the column is less than 190 mm, the acting loads must be multiplied by an additional factor γ_n indicated in Table 3, where b is the smaller dimension of the cross section of the column. For the columns analyzed, $\gamma_n = 1.35$ ($b = 120$ mm).

Table 3. Additional coefficient γ_n of NBR 6118 (ABNT, 2014)

b (mm)	≥ 190	180	170	160	150	140	130	120
γ_n	1,00	1,05	1,10	1,15	1,20	1,25	1,30	1,35

b) Applied normal force

$$N_{Sd,Eq} = \gamma_u \cdot \gamma_n \cdot N_{Sk} \quad (1)$$

$$\gamma_u = 1 + (6/b) \quad (2)$$

c) Cross section's resistant normal force

$$N_{Rd} = 0,75 \cdot f_{cd} \cdot A_c + f_{yd} \cdot A_s \quad (3)$$

$$f_{cd} = \frac{f_{ck}}{1,4} \quad (4)$$

d) Safety evaluation

$$\gamma_f = \frac{N_{Rd}}{N_{sd}} \quad (5)$$

Normal acting force (N_{Sk}) was obtained from Altoqi Eberick 2002 software and the results found with the preliminary analysis for the safety factors of the columns P21, P30 and P41 before strengthening not meet the normative safety requirements, as shown in Table 4. Figure 11 shows the interaction envelopes of resistant forces of these columns, i.e. the consideration of acting and resistant characteristic bending moments without any coefficient of increase or decrease in these actions. In this case, it is observed that the bending moments are more important and destabilize the columns (Marí & Helleland, 2005), which did not occur because the current actions were lower than those considered in the structural design up to now. It is also possible to conclude with more refined analysis that the progress of corrosion on the flexural reinforcement could significantly reduce the resistant capacity of the columns to flexure and even if the maximum designed loads did not occur, small additions could cause the loss of stability of these columns (Tang & Yang 2011), evidencing the need to strength these structural elements.

Table 4. Columns' safety coefficient before and after the structural strengthening

Column	f_{ck} (MPa)	f_{cd} (MPa)	f_{yd} (MPa)	A_c (mm ²)	A_s (mm ²)	γ_u	γ_n	N_{Sk} (kN)	$N_{Sd,Eq}$ (kN)	N_{Rd} (kN)	γ_f
P21	13.7	9.9	435	18000	482	1.5	1.35	119	240	155	0.65
P30	20.1	14.4						198	400	215	0.54
P41	14.7	10.5						176	356	164	0,46

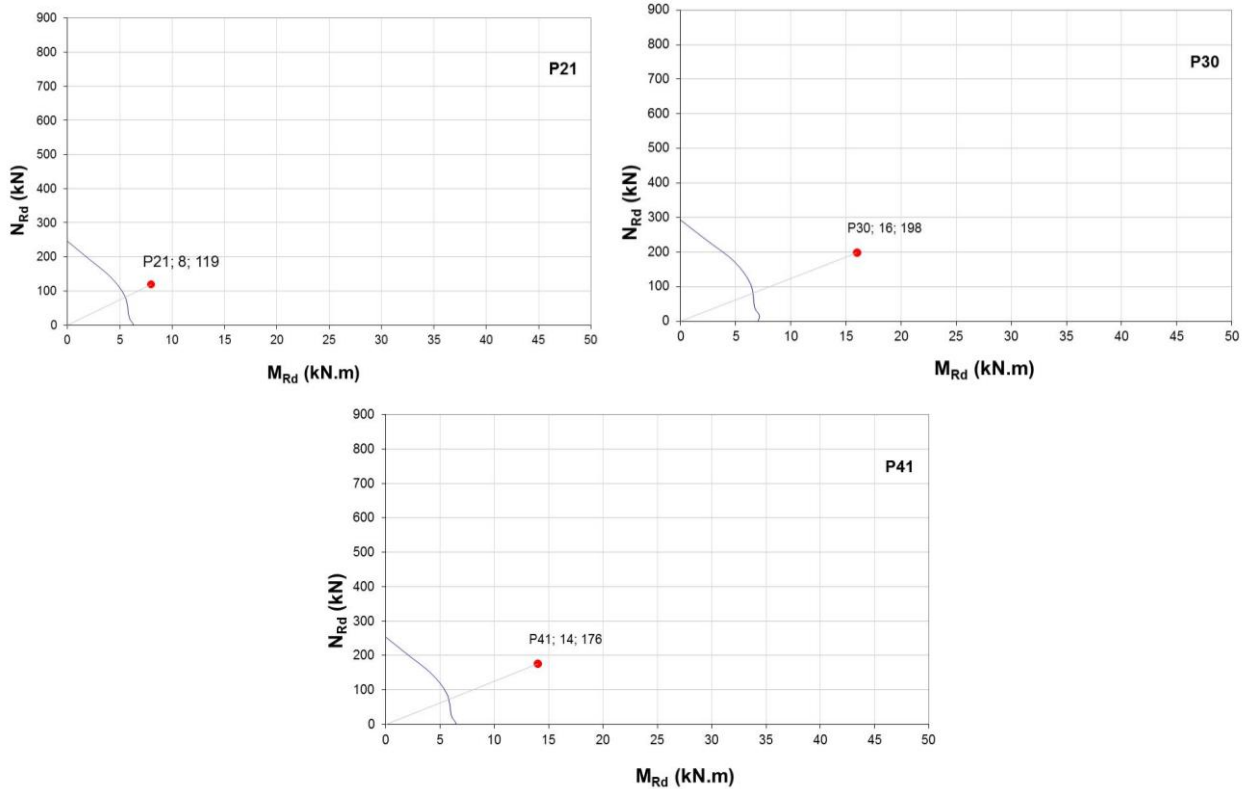

Figure 11. Envelopes for columns P21, P30 e P41 before the structural strengthening.

3.2 Strengthened columns' safety evaluation.

Columns' design safety factors for P21, P30 and P41 strengthened columns was based on the prescriptions of NBR 6118 (ABNT, 2014) following the same criteria used for the original columns without strengthening. The results are presented through the interaction envelopes of Figure 12. The safety factors of each column were determined by the ratio between the length of the straight line from the origin to the outer envelope, passing through the acting loads point, and the distance from this point to the origin, and results are presented in Table 5.

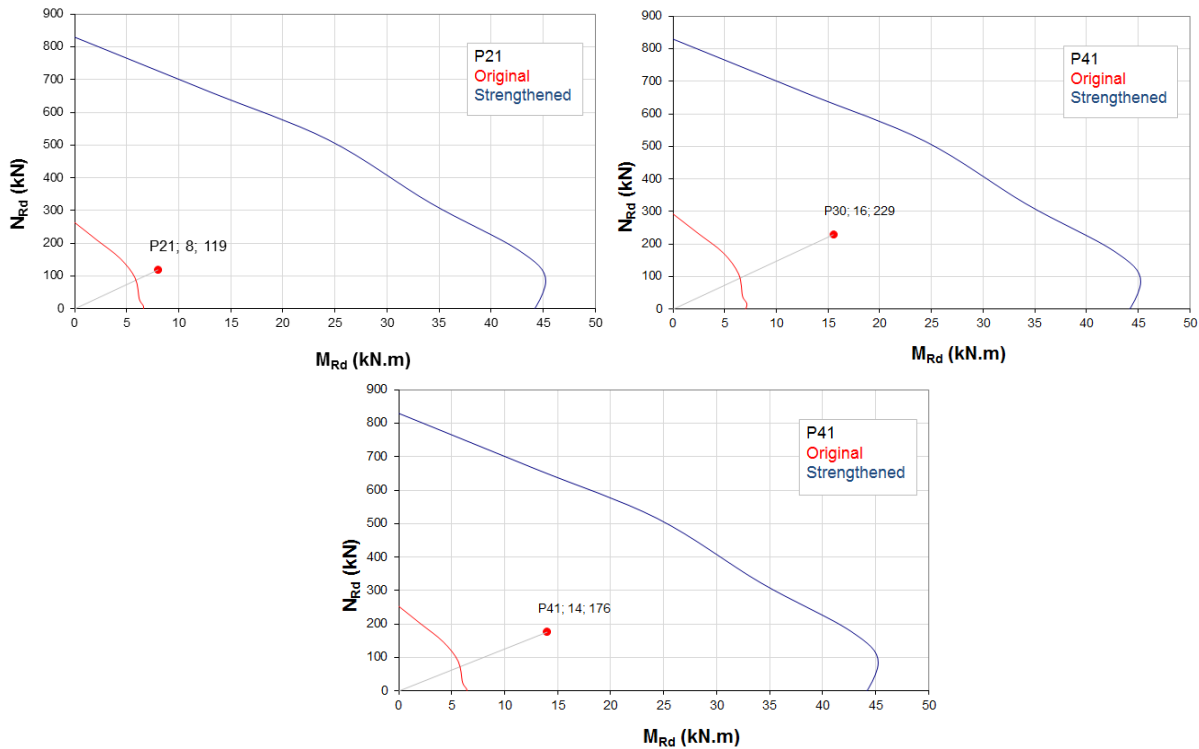

Figure 12. Envelopes' for strengthened columns P21, P30 and P41.

Table 5. Final safety factors

Column	Safety factor
P21	3.5
P30	1.8
P42	2.1

4. CONCLUSIONS

Structural problems which led to the need to strengthen the columns P21, P30 and P41 of the historic building Casarão were presented, because these columns not meet the recommendations of the Brazilian NBR 6118 (ABNT, 2014). It is considered that the structural strengthening technique proposed for these columns through the reinforced concrete jacketing was feasible because of economic advantages, speed of execution and consistency with the architectural design. Its approval was proven in the verification of normative design parameters, pointing out that the intervention performed on structural elements, however simple it may be, was preceded by structural analysis with current computer programs and increased the columns' safety of the historic building to satisfactory levels.

5. ACKNOWLEDGEMENTS

To the Program of Post-Graduate in Civil Engineering from the Federal University of Pará State, Secretary of Infrastructure and Public Works of Acre - SEOP, IPEAM, TEGAM and COC - Rio Branco.

6. REFERENCES

- Brazilian Association of Technical Standards (2014), “*NBR 6118 – Design and execution of reinforced concrete buildings*” (Rio de Janeiro, Brazil: ANBT), p. 238.
- Júlio, E. S.; Branco, F.; Silva, V. D. (2003), “*Structural Rehabilitation of Columns using Reinforced Concrete Jacketing*”, *Progress in Structural Engineering and Materials*, V.5, pp. 29-37.
- Marí, A.; Helleland, J. (2005), “*Lower Slenderness Limits for Rectangular Reinforced Concrete Columns*”, [Journal of Structural Engineering](#), V.131, pp. 85-95.
- Mehta, P. K.; Monteiro, P. J. M. (2014), “*Concreto: Microstructure, Properties e Materials*” (São Paulo, Brasil: Nicole Pagan Hasparyk), p.782.
- Tang, C. H.; Yang, Y. C. (2011), “*Loading Correlation for Reliability Analysis of Reinforced Concrete Columns*”, [Advanced Materials Research](#), V.243-249, pp.396-405.