

Development of pseudo interface element for modelling of reinforced brick masonry

S. Mehendale^{*1}, A. Bambole², S. Raghunath³*Contact Author: shashank_mehendale@smassociates.co.inDOI: <http://dx.doi.org/10.21041/ra.v7i1.147>

Received: 18-12-2016 | Accepted: 23-01-2017 | Publication: 31-01-2017

ABSTRACT

Strength of reinforced masonry is influenced by interfaces between brick, mortar and reinforcement. Experimental protocol has been defined to characterise the behaviour of reinforced brick masonry joint, with reinforcement steel embedded in cement mortar 1:6. This is applicable for low-strength, low-stiffness brick masonry found. Experimental investigations show that bond between masonry and steel is not perfect. Considering critical bond mechanisms, an attempt is made to put-forth a novel approach for development of a pseudo interface element representing three different materials (viz. brick, mortar and reinforcement) and two interfaces (reinforcement-mortar (RM) interface and brick-mortar (BM) interface). Principles of classical Reinforced Concrete (RC) design can therefore be directly applied to reinforced masonry with the introduction of the proposed pseudo interface element.

Keywords: reinforced masonry joint; interface element; masonry reinforcement bond behavior; pseudo interface material; stiffness of interface elements.

Citation: S. Mehendale, A. Bambole, S. Raghunath (2017). “Development of pseudo interface element for modelling of reinforced brick masonry”, Revista ALCONPAT, 7 (1), pp. 73-86, DOI: <http://dx.doi.org/10.21041/ra.v7i1.147>

¹ Structural Engineering Department, Veermata Jijabai Technological Institute (VJTI), Mumbai – 400 019, India.

² Structural Engineering Department, Veermata Jijabai Technological Institute (VJTI), Mumbai – 19, India.

³ Civil Engineering Department, BMS College of Engineering, Bangaluru – 560 019, India.

Legal Information

Revista ALCONPAT is a quarterly publication of the Latinamerican Association of quality control, pathology and recovery of construction- International, A.C.; Km. 6, Antigua carretera a Progreso, Mérida, Yucatán, C.P. 97310, Tel.5219997385893.

E-mail: revistaalconpat@gmail.com, Website: www.revistaalconpat.org.

Editor: Dr. Pedro Castro Borges. Reservation of rights to exclusive use No.04-2013-011717330300-203, eISSN 2007-6835, both awarded by the National Institute of Copyright. Responsible for the latest update on this number, ALCONPAT Informatics Unit, Eng. Elizabeth Maldonado Sabido, Km. 6, Antigua carretera a Progreso, Mérida, Yucatán, C.P. 97310.

The views expressed by the authors do not necessarily reflect the views of the publisher.

The total or partial reproduction of the contents and images of the publication without prior permission from ALCONPAT International A. C. is not allowed.

Any discussion, including authors reply, will be published on the first number of 2018 if received before closing the third number of 2017.

Desarrollo de un pseudo-elemento de interfaz para el modelado de mampostería de ladrillo reforzado

RESUMEN

La resistencia de la mampostería reforzada está influenciada por las interfaces entre el ladrillo, el mortero y el refuerzo. Se ha definido un protocolo experimental para caracterizar el comportamiento de la junta de mampostería de ladrillo reforzado, con acero de refuerzo incrustado en mortero de cemento 1: 6. Esto es aplicable para la albañilería con ladrillos de baja resistencia y baja rigidez encontrada. Las investigaciones experimentales demuestran que el vínculo entre la mampostería y el acero no es perfecto. Teniendo en cuenta los mecanismos de enlace críticos, se intenta presentar un nuevo enfoque para el desarrollo de un elemento de pseudo-interfaz que represente tres materiales diferentes (ladrillo, mortero y refuerzo) y dos interfaces (de refuerzo y mortero (RM) y de mortero (BM)). Por lo tanto, los principios del diseño de concreto armado (RC) clásico pueden aplicarse directamente a la mampostería reforzada con la introducción del pseudo-elemento de interfaz propuesto.

Palabras clave: articulación de mampostería reforzada; elemento de interfaz; comportamiento de enlace de refuerzo de mampostería; pseudo-material de interfaz; rigidez de los elementos de la interfaz.

Desenvolvimento de elemento de pseudo interface para modelagem de alvenaria de tijolo armado

RESUMO

A resistência da alvenaria reforçada é influenciada pelas interfaces entre tijolo, argamassa e armadura. O protocolo experimental foi definido para caracterizar o comportamento de juntas de alvenaria de tijolo armado, com aço embutido em argamassa de cimento 1:6. Isto é aplicável para baixa resistência, com tijolo de baixa rigidez. Investigações experimentais mostram que a ligação entre a alvenaria e o aço não é perfeita. Considerando os mecanismos de ligação críticos, é feita uma tentativa de apresentar uma nova abordagem para o desenvolvimento de um elemento de pseudo interface representando três materiais diferentes (tijolo vizinho, argamassa e armadura) e duas interfaces (interface argamassa-armadura (RM) e interface tijolo-argamassa (BM)). Os princípios de projeto clássicos de concreto armado (RC) podem, portanto, ser diretamente aplicados à alvenaria armada com a introdução do elemento de pseudo interface proposto.

Palavras chave: junta de alvenaria armada; elemento de interface; comportamento de ligação de reforço de alvenaria; material de pseudo interface; rigidez dos elementos de interface.

1. INTRODUCTION

Masonry is a brittle construction material that has been used for a very long time around the world and is still being used. Over the period, masonry is used as vertical load carrying elements due to excellent performance in compression. Limited tensile capacity of masonry is generally overcome by using arches, vaults, etc. over opening. These arches, vaults convert flexural tension into compression due to their geometry. In comparison, concrete is also a brittle material with limited tensile capacity and generally this limitation is overcome by the introduction of reinforcing steel or by pre-stressing. Similar use of reinforcement in masonry construction is not new, but is uncommon in India. Reinforcement can be introduced in masonry elements in several ways. The most common method is to place reinforcing bars in the bed joints. Structural members built in this

way can be used to resist flexural forces (loads), in the form of beam. Most of the codes available for reinforced masonry are based on principles and assumptions of Reinforced Concrete (RC) design. Main assumption of classical RC design is that, the tensile force is resisted by reinforcement alone and bond between reinforcement and concrete is nearly perfect.

Literature on brick masonry reveals that in western countries bricks are more stiff and stronger than mortar used. Compressive strength of such bricks may be in the range of 15-150 MPa and elasticity modulus in the range of 3500-35000 MPa. Whereas in India, bricks have relatively less compressive strength (3-20 MPa), and elastic modulus (300-15000 MPa). Also, the commonly used cement mortar (1:6) generally have elasticity modulus 10 to 15 times higher than that of bricks (Matthana, 1996), (Sarangapani et al, 2005), (Raghunath et. al., 1998) and (Gumaste et al, 2004). Laurenco 1994, has enlisted various models to predict behaviour of unreinforced masonry. Laurenco recommended Coloumb friction model with compression cap for interface between mortar and brick. Globally, classical RC theory is used for modelling reinforced masonry (Narendra Taly, 2010).

Typically, reinforced brick masonry in flexure is achieved by inserting reinforcement in bed joint at certain depth. The joint assemblage in reinforced masonry comprises of five elements viz. (i) reinforcement, (ii) reinforcement-mortar interface, (iii) mortar, (iv) mortar-brick interface and (v) brick (units). These are shown schematically in Figure 1.

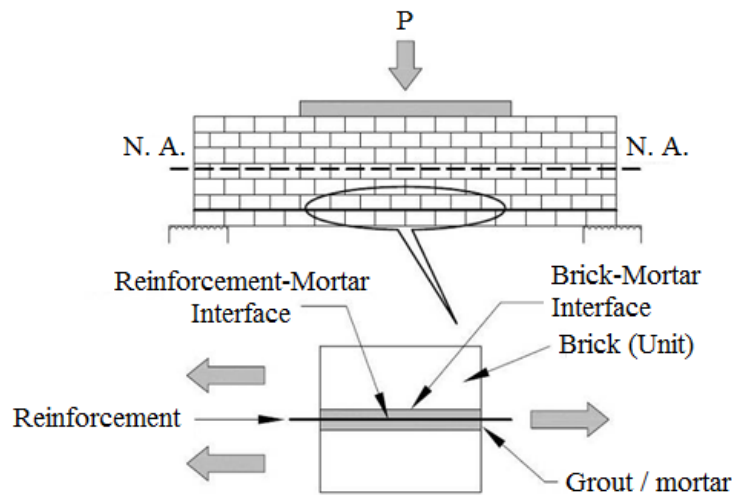

Figure 1. Typical reinforced masonry beam and reinforced masonry joint details.

Experimental investigations performed on reinforced brick masonry (Shashank Mehendale et. al. 2016) show that, bond between reinforcement and brick masonry is not perfect. Different shear deformations are being observed due to variation in shear properties of individual elements and interfaces between them; leading to loss in strain and less force is developed in the reinforcement as compared to a scenario of perfect bond. Thus, the contribution of reinforcement in reinforced masonry beam is likely to be lesser than that of RC beam. It is observed that weakest links in reinforced masonry are the interfaces between brick, mortar and reinforcement. In reinforced masonry design, use of classical assumptions of design of RC may lead to over reliance on reinforcement. The need for novel approach for design of reinforced masonry beam is felt for low strength type bricks and mortars used in the study. Considering the importance of interfaces, detailed investigation of individual elements of reinforced masonry joint in similar test environment was carried out. Based on the results of experimental work on individual elements and assemblage, an attempt is made to develop a pseudo interface element. The present work aims at using experimental observations of individual elements and merging the same into a pseudo interface by suitably capturing the contribution of each of the elements in the assemblage. The

proposed pseudo interface element can be lumped with masonry, thereby improving predictions about contribution of reinforcement. The purpose of the present research is to study and develop design protocol, which will help to achieve the optimum utilisation of material and efficient joint.

2. EXPERIMENTAL INVESTIGATION

Behaviour of reinforced masonry joint is investigated using experimental protocol presented in this study. Pull-out test is widely used as an effective means for the characterization of the bond behaviour between internally bonded reinforcements and masonry. An indigenously developed test set-up shown in Figure 2 (a) and (b) are used to study the behaviour of reinforced masonry assemblage using facilities available in VJTI laboratory.

Locally available country moulded bricks with cement mortar 1:6 has been used for preparation of samples. Water cement used in mortar was based on flow test. 8mm diameter HYSD steel bar were placed at centre of 20 mm thick mortar layer in assemblage. A counter weight of 2 bricks was maintained over each sample for 4 days to ensure proper bonding between mortar and bricks. The samples were cured for 14 days. Expected over burden pressure in in-situ condition is simulated in tests by applying confining pressure to samples. Over burden pressure generally found to be around 0.5 N/mm^2 (Laurenco 1994) was used in present experimental investigation. Pull-out force was applied using strain controlled device and deformation (displacements) response was recorded.

Figure 3 shows the plot of pull-out force vs. Displacement of the reinforcement. It is observed that pull-out force of varies with displacement of reinforcement bar almost linearly up to peak value of force, thereafter, softening is observed as displacement increases. It can be noticed that some residual buffer capacity exists due to skin friction effect. It is observed from experiments that the residual buffer capacity is a function of confining pressure. As the properties of the masonry unit is not consistent even in a single lot, 20 numbers of tests were planned to get representative and reliable results.

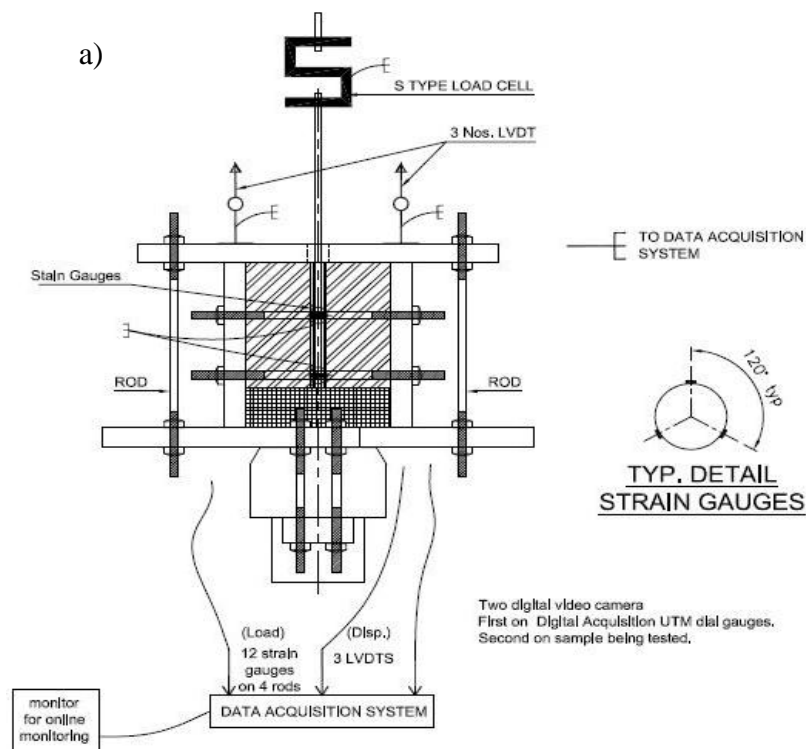



Figure 2. (a) Sample held in position (b) Pull-out Test set-up

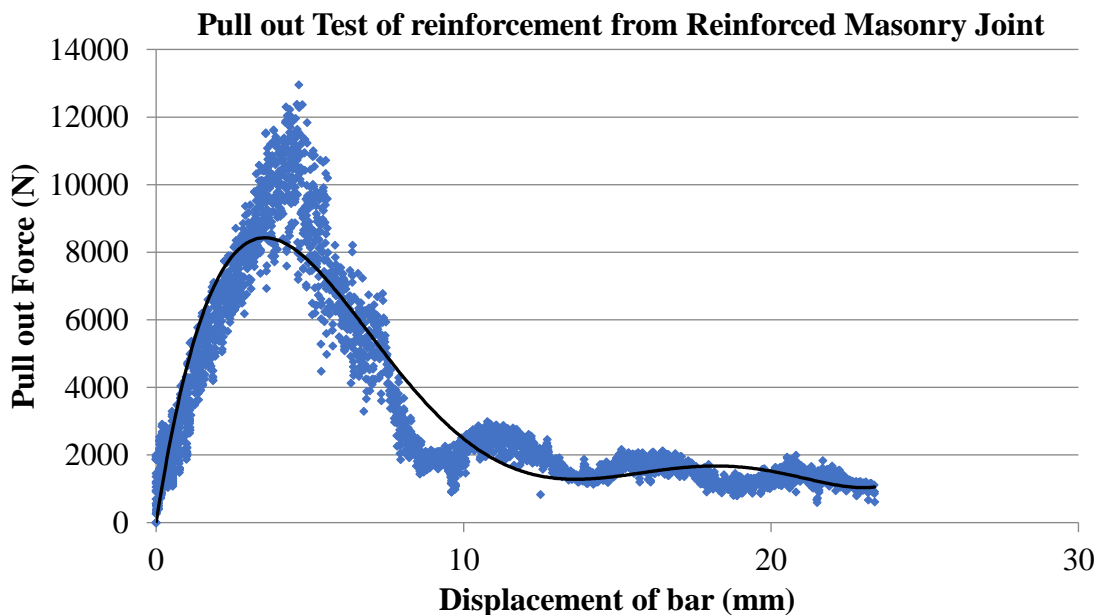

Figure 3. Results of Pull-out Test on assemblage.

The pull-out capacity of bar embedded in assemblage and associated stiffness depends on the complex interaction between individual elements viz. brick, mortar, reinforcement and interface between brick and mortar and interface between reinforcement and mortar. This behavior is found to be different than that in an RC member. It is observed that strain in extreme fiber brick masonry is not fully transferred to reinforcement due to shear slippage of quasi-brittle material viz. brick and mortar.

To study the various parameters affecting pull-out capacity and stiffness; based on the available literature (Laurenco, 1994), various test set-ups have been fabricated and experiments were performed to determine the properties of units, mortar, reinforcement and interfaces used. Details of set-ups and experimental protocol is briefly described in this study. Table 1 shows the properties of basic elements used in study, which represents the reinforced masonry joint.

Table 1. Properties of Materials used in study

Tests	Brick	Mortar (1:6)	Reinforcement (8mm dia.)
Compressive Strength (MPa) (Number of Specimens)	3.88 (8)	8.32 (06)	-
Flexure Strength (MPa) (Number of Specimens) Note: loaded along depth	0.98 (6)	2.42 (06)	-
E_{initial tangent} (MPa)	142.2	15401.6	2 X 10 ⁵
Tensile Strength (MPa)	-	0.96	415

A. Tensile Test on Reinforcement

Tensile test on reinforcement was carried out using procedure prescribed in IS 1786 (2008). Axial stiffness of reinforcement is a contributing parameter.

B. Pull-out Test of Reinforcement from Mortar alone

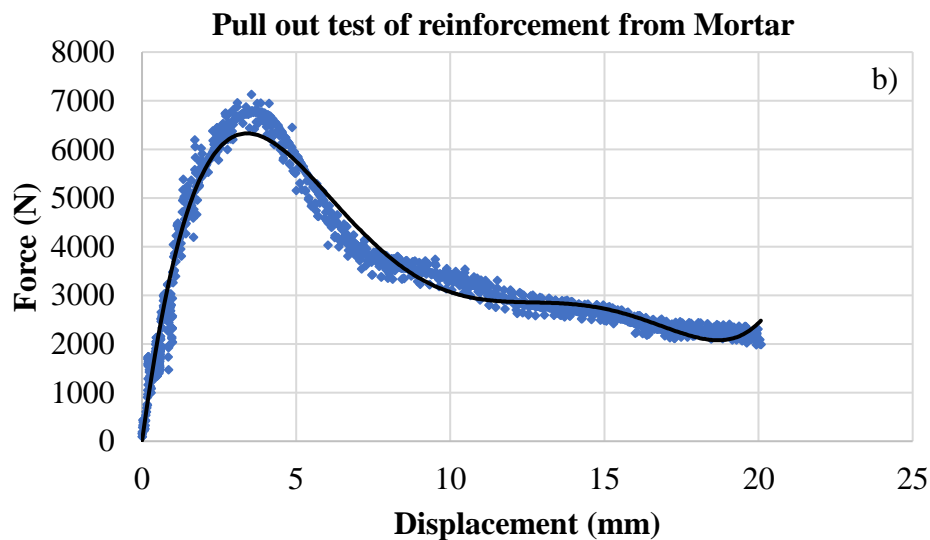
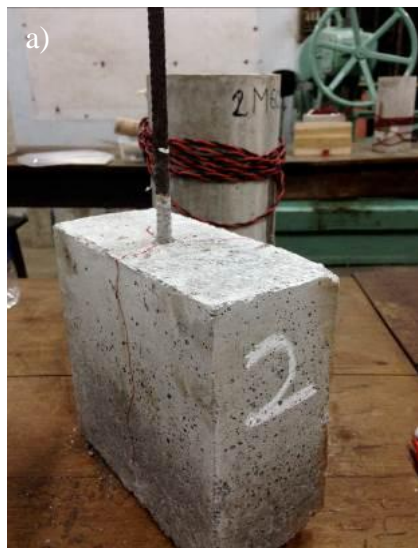

Figure 4. (a) Specimen (b) Results of Pull-out Test of R/f from Mortar

Pull-out test of reinforcement from mortar was carried out using the above referred test set-up. Sample size used was same as that of the assemblage (160mm x 200mm x 90mm), with reinforcement placed at center. This test is used to determine reinforcement mortar interface properties. Confinement pressure of 0.5 N/mm² is applied using tension bolts. Figure 4 shows the plot of pull-out force in reinforcement vs. displacement.

C. Mortar double shear test

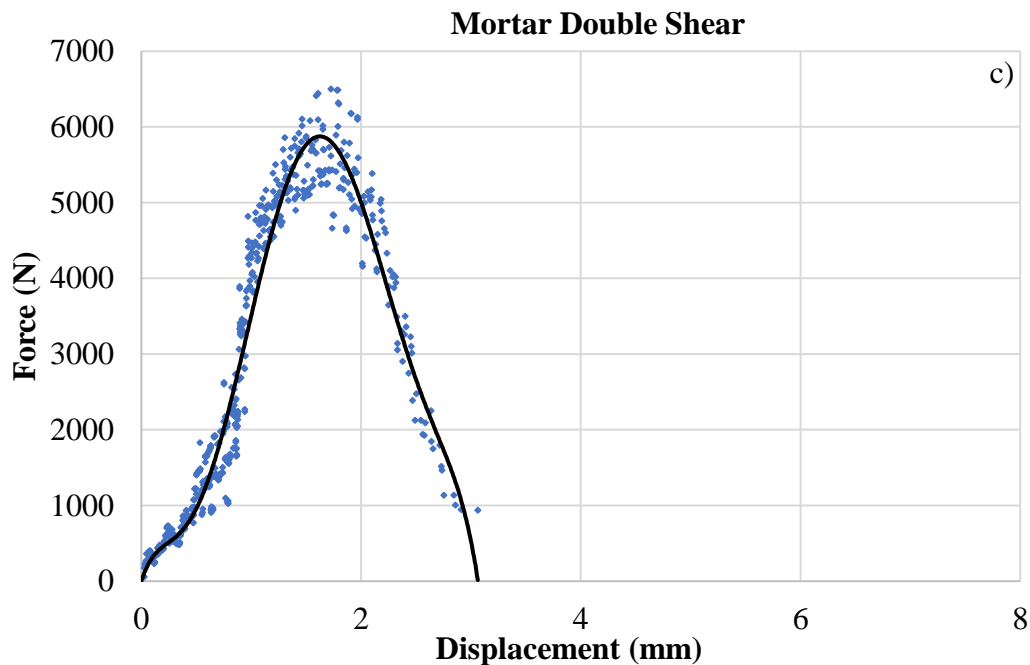
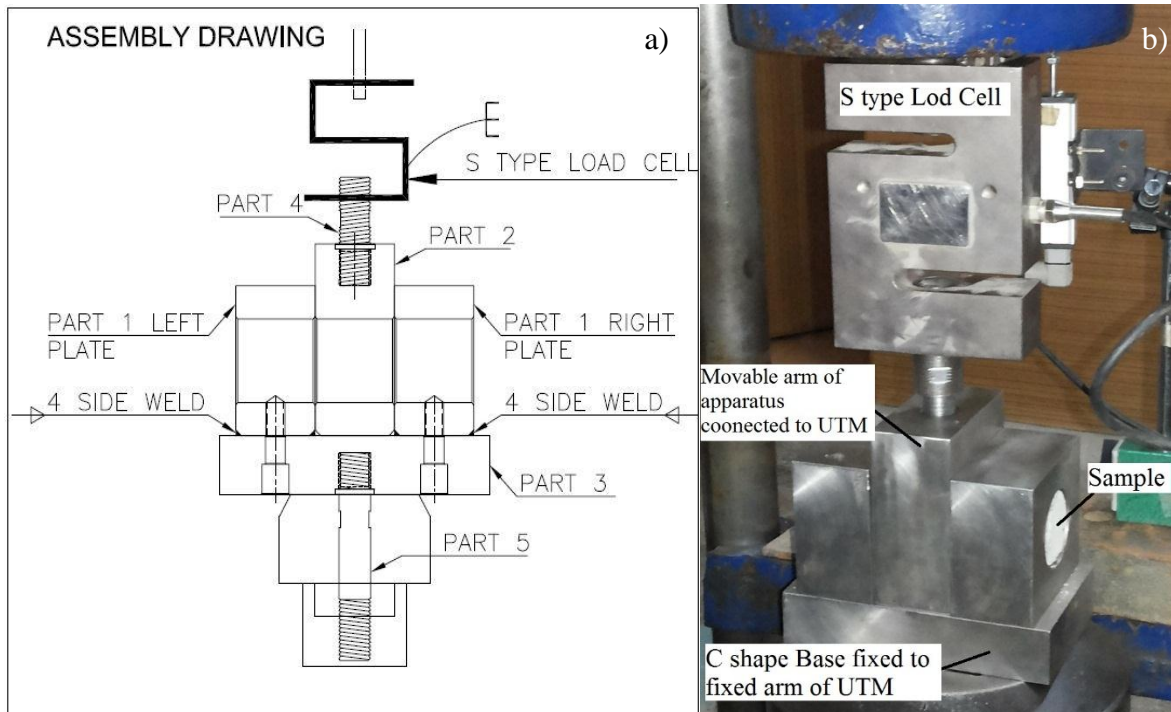

Figure 5. (a) Schematic Mortar Shear Test Set up, (b) actual photograph (c) Results

Mortar shear contribution is established using indigenously developed Mortar Double Shear Apparatus. This apparatus is based on concept of double shear, often used in soil mechanics. Sample size of 50mm diameter mortar cylinder with 150mm length was adopted. Apparatus, shown in Figure 5, consist of 2 main elements, lower element (C shape) consists of part 1 (left and right plate) and part 3 are attached to fixed arm of UTM. Top element labelled as part 2 is attached to movable arm of UTM thru load cell.

D. Brick-Mortar Interface Shear Test

Brick-Mortar interface shear test has been carried out with confinement pressure applied, using the arrangement shown in figure 6. Epoxy was used to ensure perfect bond between sample and apparatus. Shear contribution of brick-mortar interface is calculated using shear test apparatus suggested by P B Launreco, (1994) and Van der Plujim, (1992 & 1993).

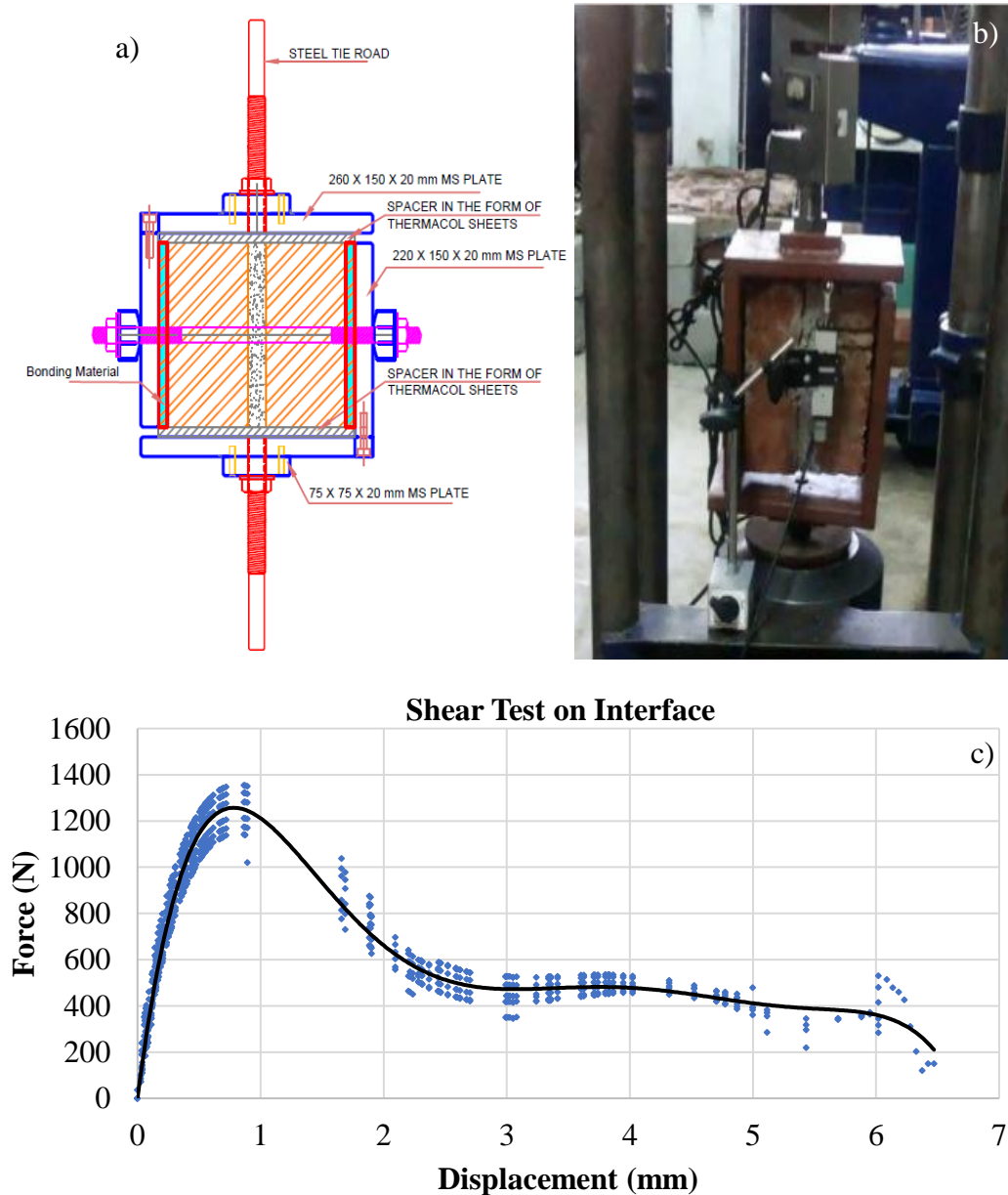

Figure 6. Shear Test on Brick Mortar Interface (a) Schematic Test set-up (b) Actual photograph (c) Results

E. Brick Shear Test

Brick shear contribution is worked out from direct shear test concept commonly used in geotechnical engineering. Confinement pressure plays an important role in shear strength evaluation. In all the above mentioned experiments, a confinement pressure 0.5 N/mm^2 has been used brick samples of $50 \text{ mm} \times 50 \text{ mm}$ cross-section were cut carefully from brick units. The test set-up, failure pattern observed and test results are shown in figure 7 (a), (b) and (c) respectively.

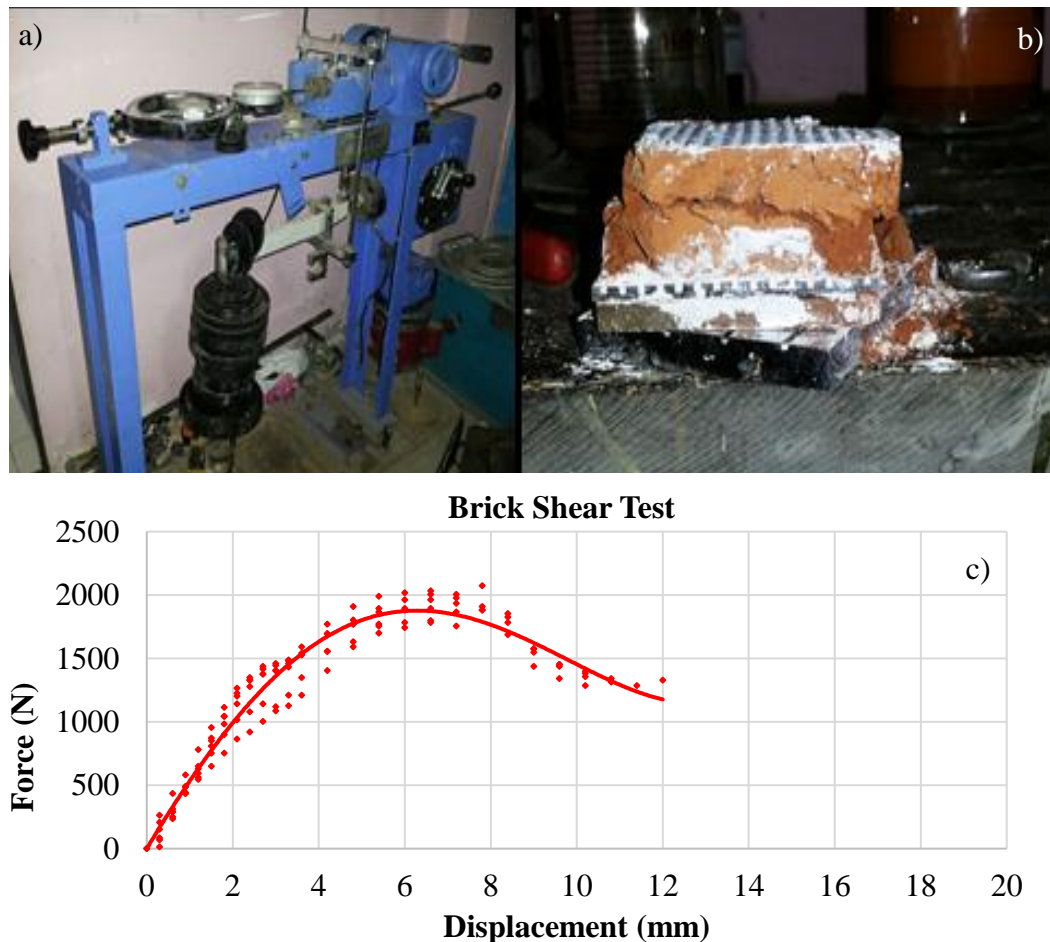

Figure 7. (a) Brick shear test test set-up, (b) Typical shear failure observed and (c) Brick Shear Test Results

The large deformations observed are not relevant to design process as structure would have failed by the time large deformations take place. Thus, the attempt of designer is to keep deformations within control and as minimum as possible. Within such controlled and limited range of deformations behavior of individual elements and interfaces can be assumed to linearly elastic. Thus, it can be idealized as discrete springs.

An idealization using spring analogy has been put forth to simplify the complexity due to contribution of five elements of the assemblage. Pull-out force remains constant across all the elements and deformation is a function of the resistance offered by reinforcement, reinforcement-mortar interface, mortar, mortar-brick interface and brick resistance. Each contributing parameter can be idealized as discrete springs and the entire assemblage can be idealized as system of springs connected in series. Thus, the effective stiffness of assemblage is a contribution of stiffness of reinforcement, shear stiffness of RM bond, shear stiffness of mortar, shear stiffness of BM bond

and shear stiffness of brick. A schematic representation of the above-mentioned idealization is represented in Figure 8.

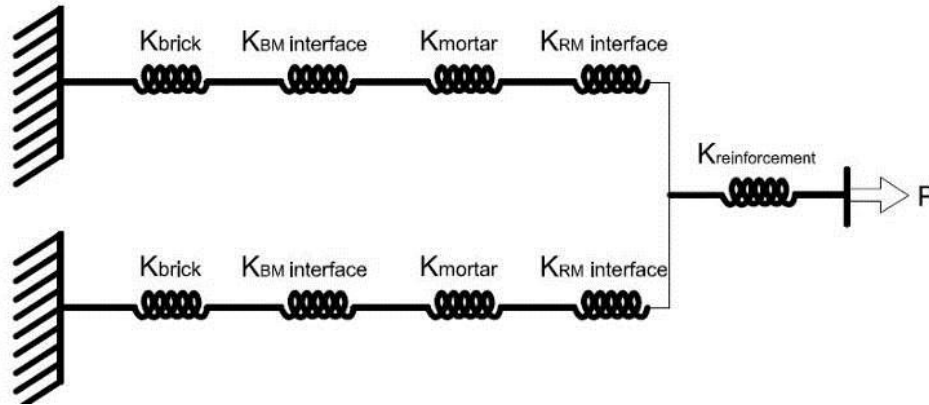

Figure 8. Spring Analogy

3. EXPERIMENTAL FINDINGS AND INFERENCE

All tests were performed using displacement controlled machine at VJTI, Structural Engineering laboratory. A plot of Force vs. Displacement graphs were obtained for each test. Stiffness values of each contributing element have been calculated and tabulated in Table 2.

It is observed that there is good correlation between the experimental stiffness for the said joint and the results obtained using analytical model using spring idealization. Spring formulas for springs in parallel and series in combination for the above assemblage of springs shown in Figure 8 can be represented as follows using Equation (1) and Equation (2);

$$\frac{1}{k_{Eq,pseudomaterial}} = \frac{1}{k} + \frac{1}{k_{reinforcement}} \quad (1)$$

Where, k is equivalent spring constant for springs in parallel.

$$\frac{1}{k} = \frac{2}{\frac{1}{k_{RM\ interface}} + \frac{1}{k_{mortar}} + \frac{1}{k_{BM\ interface}} + \frac{1}{k_{brick}}} \quad (2)$$

Equation (1) and Equation (2) are valid within elastic bounds of each springs, i. e.

$$P \leq P_R^L, P_{RM}^L, P_M^L, P_{BM}^L, P_B^L \quad (3)$$

Where,

P_R^L (limiting elastic load on reinforcement spring)

= Limiting elastic stress of Reinforcement x C/s area of reinforcement

P_{RM}^L (limiting elastic load on RM interface spring)

= Limiting elastic stress of spring equivalent to RM interface x C/s area of RM interface

P_M^L (limiting elastic load on mortar spring)

= Limiting shear stress of spring equivalent to Mortar x C/s area of mortar in shear

P_{BM}^L (limiting elastic load on BM interface spring)

= Limiting stress of spring equivalent to BM interface x C/s area of BM interface

P_b^L (limiting elastic load on brick spring)

= Limiting shear stress of spring equivalent to Brick x C/s area of brick in shear

Breach of any of these bounds i.e. failure of any of above listed idealized springs shall predict the corresponding failure mode e.g. failure of RM spring will indicate failure of interface between reinforcement and mortar.

Table 2. Stiffnesses Matrix (Experimental and formula based).

Experimental Element stiffness	Initial tangent Stiffness
$K_{\text{reinforcement}}$	25120 N/mm
$K_{\text{RM interface}}$	3521.1 N/mm
K_{Mortar}	2857.1 N/mm
$K_{\text{BM interface}}$	6666 N/mm
K_{Brick}	714 N/mm
$K_{\text{Eq. pseudo material (from Formula)}}$	883.77 N/mm
$K_{\text{Eq. pseudo material (Pull-out test)}}$	981 N/mm

This correlation using spring analogy can be used to model pseudo interface element with effective stiffness equivalent to that of reinforced masonry joint.

3.1 Relationship to Elasticity

Spring analogy idealization presented above forms the basic approach for development of a novel formulation for modelling pseudo interface material for reinforced brick masonry joint. The joint in flexural formulation resists tension where the masonry takes the compression. Thus, the joint can be considered to be subject to tension alone. The stiffness k , of a body is a measure of the resistance offered by an elastic body to deformation and is thus ratio of force applied to the deformation produced. In mechanics, the Elastic modulus (Young’s Modulus) is an intrinsic property of material that is computed as the ratio of stress to strain, i.e.

$$E = \frac{\sigma}{\varepsilon} \tag{4}$$

substituting values for σ and ε , $E = \frac{F/A}{\Delta/l}$ i.e.

$$E = \frac{Fl}{A\Delta} \tag{5}$$

From above assumptions and rearranging the terms, above equation can be restated as

$$E = \left(\frac{F}{\Delta}\right)\left(\frac{L}{A}\right) \tag{6}$$

$$\text{i.e. } E = K \frac{l}{A} \quad (7)$$

Thus, tension modulus of elasticity for pseudo material can be written in terms of reinforced masonry joint stiffness k using Equation (4) as follows,

$$E_{Eq.pseudomaterial} = \frac{L}{A} k_{Eq.pseudomaterial} \quad (8)$$

Substituting experimental stiffness values of pseudo interface element, the modulus of elasticity of pseudo interface element will be, (for unit length reinforced masonry beam with unit cross sectional area), $E_{eq.pseudomaterial} = 883.77 \text{ MPa}$.

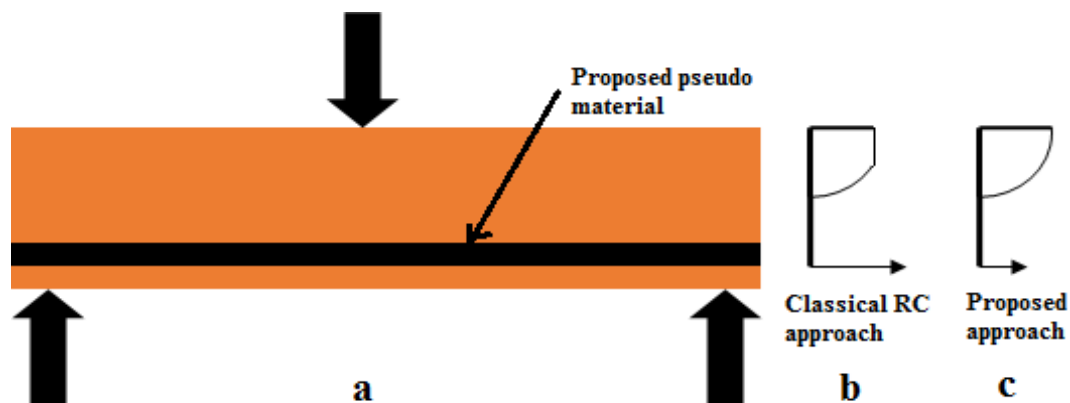

Figure 9. Typical reinforced masonry beam with stress relationship b) Stress diagram as per RC design assumption, c) Stress diagram as per study with discounted tensile force and masonry stress block.

Comparison of stress block for reinforced masonry using classical RC design approach (figure 9 b) and proposed formulation for modelling interface of reinforced masonry (figure 9 c) is shown in figure 9. In classical design approach reinforcement yields first and allowed to take load upto its yielding capacity. Where as in this approach, the pseudo interface element yields when one of the interface boundary conditions is breached. This results in relatively lesser contribution by reinforcement as compared to classical RC design. Thus, a reinforced masonry beam would require larger depths and profiled reinforcement grouted into masonry so as not to breach the interface boundary condition and this approach is leads to optimum solution.

4. CONCLUSION

Investigations performed on reinforced masonry with focus on the materials viz. unit, mortar and reinforcement and interfaces indicates following features.

- i) Bond between reinforcement bar and masonry is not perfect.
- ii) Due to relative shear deformations loss in strain occurs and thus less force is developed in the reinforcement bar.
- iii) Relative shear deformations are observed due to different shear properties of individual elements and interfaces between them.
- iv) Developed pseudo interface element predicts likely failure modes.

Behavior of reinforced masonry is different from RC, hence assumptions of classical RC design cannot be directly used for considered masonry units. This difference would be more for weak bricks and weak mortars. Considering the complexity of reinforced masonry joint, this study has presented an approach to develop a pseudo interface element representing 5 different elements of a reinforced masonry joint. This pseudo interface element would help in design and modelling of reinforced masonry in flexure. Though, tests are carried out on particular type of brick (unit), mortar/ grout and reinforcement, the experimental protocol and proposed approach for development of pseudo interface element in this study is robust enough and can be used to other types of units, mortars and reinforcing materials. Same approach might be helpful in similar type of conditions to simplify interface complexities. The developed pseudo interface element would help engineers to arrive at the most suitable and economical reinforced masonry solution.

5. ACKNOWLEDGEMENTS

The author¹ gratefully acknowledge Veermata Jijabai Technological Institute, Mumbai, India and BMS Collge of Engineering, Banglore, India for providing the test facilities and materials used in this study. The support by the lab technicians and assistants of these laboratories is also acknowledged.

6. REFERENCES

- Arezoo Razavizadeh, Bahman Ghiassi, Daniel V Oliveira (2014), *Bond behavior of SRG-strengthened masonry units: Testing and numerical modeling*. Construction and Building Materials 64 (2014) 387–397 https://en.wikipedia.org/wiki/Flexural_modulus.
- Gumaste K. S., Venkatarama Reddy B. V., Nanjunda Rao K. S., Jagadish K. S. (2004), *Properties of burnt bricks and mortars in India*. Masonry Int 17(2):45–52.
- Hendry A. W. (1998), *Structural masonry*. Macmillan Press, London.
- Van Noort J. R. (2012), *Computational modelling of masonry structures*, Delft University of Technology, Master Thesis.
- Lenczner D. (1972), *Elements of load bearing brickwork*, Pergamon, Oxford.
- Matthana M. H. S. (1996), *Strength of brick masonry and masonry walls with openings*. Ph D thesis, Department of Civil Engineering, Indian Institute of Science, Bangalore, India.
- Narendra T. (2010), *Design of masonry structures*, 2nd Edition, International Code Council.
- Lourenço P. B. (1994), *Computational strategies for masonry structures*, PhD Thesis, Faculdade de Engenharia da Universidade do Porto, Portugal.
- Van Der Pluijm, R. (1992), *Material properties of masonry and its components under tension and shear*, in: Proc. 6th Canadian Masonry Symposium, eds. V.V. Neis, Saskatoon, Saskatchewan, Canada, p. 675-686.
- Pluijm, R. Van Der (1993), *Shear behavior of bed joints*, in: Proc. 6th North American Masonry Conf., eds. A. A.
- Hamid and Harris H. G. (1993), Drexel University, Philadelphia, Pennsylvania, USA, p. 125-136.
- Raghunath S., Jagadish K. S. (1998), *Strength and elasticity of bricks in India*. Workshop on Recent Advances in Masonry Construction: WRAMC-98, Roorkee, India:141–150.
- Sarangapani G., Venkatarama Reddy B. V., Jagadish K. S. (2005), *Brick–mortar bond and masonry compressive strength*. J Mater Civil Eng (ASCE) 17(2):229–237.
- Mehendale S., Bambole A., Raghunath S. (2016), *Studies on Pull-Out Resistance of Reinforcement in Bed-Joint of Brick Masonry*, 10th International Conference on Structural Analysis of Historical Constructions –Anamnesis, diagnosis therapy, controls – Van Balen & Verstryngne (Eds) © 2016 Taylor & Francis Group, London, ISBN 978-1-138-02951-4, page 1093 - 1098

<https://en.wikipedia.org/wiki/Stiffness>

Is 1786: 2008, *High strength deformed steel bars and wires for concrete reinforcement* — Specification (Fourth Revision).